

Trade Mark:  
CRYSTAL WORLD INC

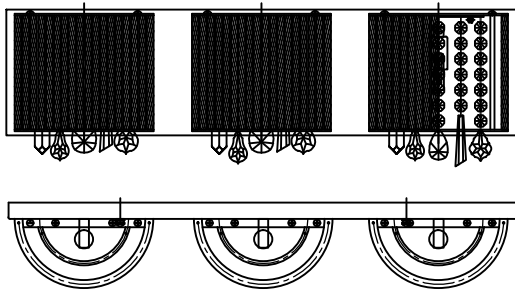

Product Name: Wall lamp  
Model :5562W25C-3  
120Vac, 60Hz,AC ONLY  
Lamp Size:W25"\*H7"\*E4"



## WALL LAMP ASSEMBLY INSTRUCTIONS

1. Place fixture(A) onto Butterfly (EE).  
Secure(DD) with cap nuts (AA).  
Install glass shade .

### Hardware Used

|                   |   |     |
|-------------------|---|-----|
| AA Cap nut        |  | X 2 |
| DD Mounting screw |  | X 4 |

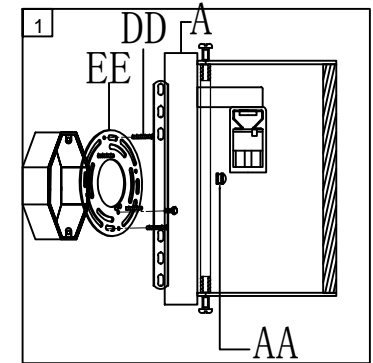

2. Please wear gloves  
when you hanging the crystal.

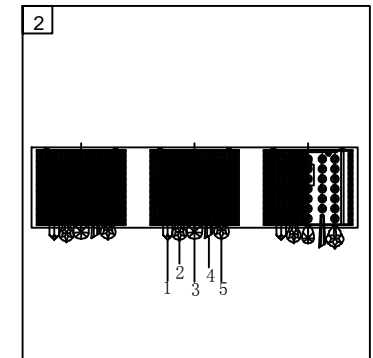
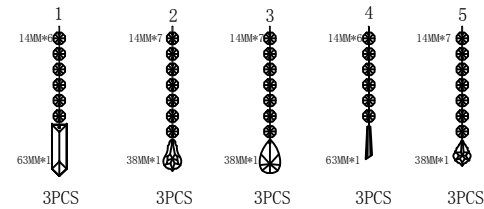

3. Install light bulbs ( not included).  
Use bulb  
**120V G9 3\*40W Max.**

